

1
2
3
4
5
6

5150

- Einstellbar und fixierbar unter jedem Winkel von 0-90°
- Die Fixierung erfolgt mit Hilfe von 2 Halteschrauben
- Easily set at any angle between horizontal and vertical plates
- The plate will accept accessories and workpieces larger than setting in the table top

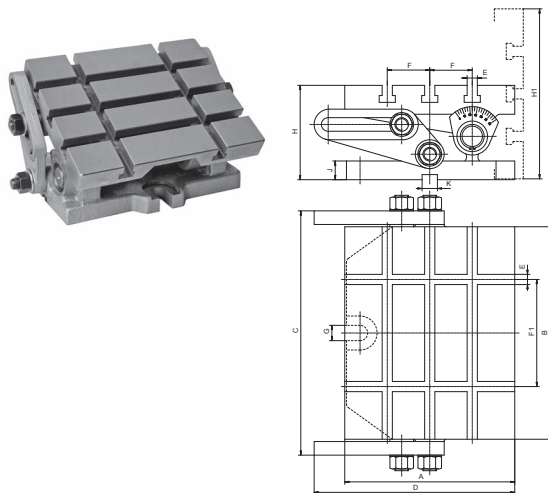

Artikel Nr. Code No.	Typ Type	A	B	C	D	E	F	F1	G	H	H1	J	K	Max. Bearbeitungsgewicht Max. working weight	kg
375150010300	5150-200x250	200	250	324	236	12	50	126	18	111	201	22	18	60	21
375150020500	5150-250x315	250	315	405	306	14	63	160	18	127	252	25	18	100	37

5155

- Einstellbar und fixierbar unter jedem Winkel von 0-90°
- Der Spanntisch 5155 (Sinustisch) erlaubt zusätzlich die exakte Winkeleinstellung von 0-60° unter Einsatz von Endmaßen
- Easily set at any angle between horizontal and vertical plates
- Swivel plates type 5155 (sine) permit accurate angle setting in 0-60° range by means of gauge blocks

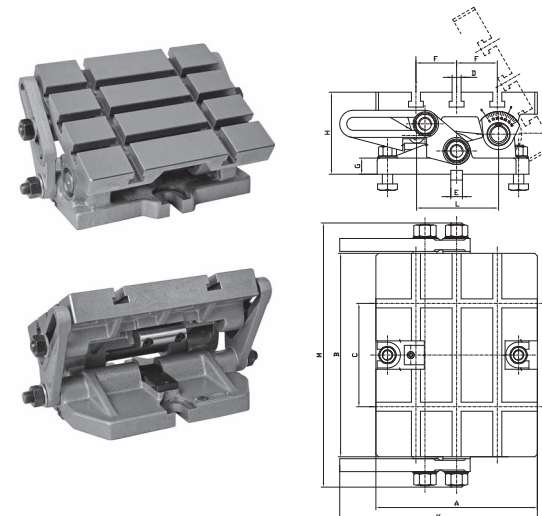

Artikel Nr. Code No.	Typ Type	A	B	C	D	E	F	G	H	K	L	M	Max. Bearbeitungsgewicht Max. working weight	kg
75155010400	5155-200x250	200	250	126	12	18	50	22	111	236	100	324	60	21
75155020600	5155-250x315	250	315	160	14	18	63	25	127	306	127	405	100	37

9450

GRUNDPLATTEN BASES

Standardzubehör

- Nutensteine
 - Befestigungsschrauben
- #### Standard accessories
- Slot nuts
 - Clamping bolts

FÜR DIN 6350
FOR DIN 6350

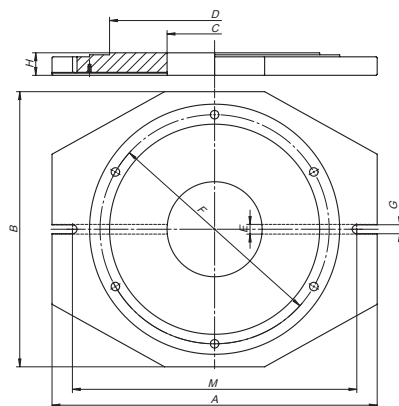

Artikel Nr. Code No.	Typ Type	Futter Größe Chuck Size	A	B	C	D	d	E	F	G	H	M	kg
329450040700	9450-160	160	250	190	90	125	11	18	140	14	28	224	4,8
329450050900	9450-200	200	300	234	130	160	11	18	176	18	32	264	7,5
329450060000	9450-250	250	354	292	147	200	14	18	224	18	32	322	11,5
329450070200	9450-315	315	426	362	170	260	17	18	286	18	40	394	16,0
329450080400	9450-400	400	520	450	170	330	17	18	362	18	48	488	23,0
329450090600	9450-500	500	640	560	240	420	17	18	458	17	48	608	57,5

9454

DREHPLATTEN SWIVEL BASES

Standardzubehör

- Nutensteine
 - Befestigungsschrauben
- #### Standard accessories
- Slot nuts
 - Clamping bolts

FRONTSEITIGE MONTAGE
FOR FRONT MOUNTING

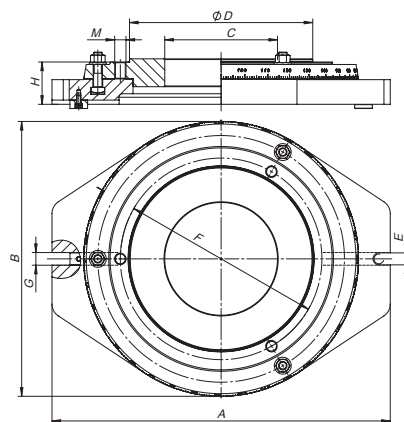

Artikel Nr. Code No.	Typ Type	Futter Größe Chuck Size	A	B	C	D	E	F	G	H	M	kg
329454040000	9454-160	160	312	235	80	125	18	140	17	54	3xM10	15,5
329454050100	9454-200	200	347	270	120	160	18	176	17	54	3xM10	21,3
329454060300	9454-250	250	400	324	160	200	18	224	17	55	3xM12	35,0
329454070500	9454-315	315	480	380	160	260	18	286	17	60	3xM16	41,0
329454080700	9454-400	400	565	475	245	330	18	362	17	70	3xM16	65,0
329454090900	9454-500	500	665	575	345	420	18	458	17	73	3xM16	84,0